

PLAN AT C-C

PLAN AT D-D

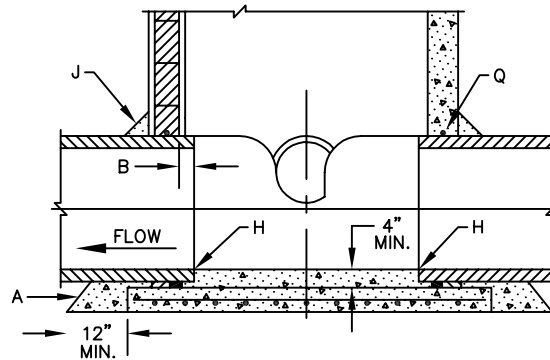
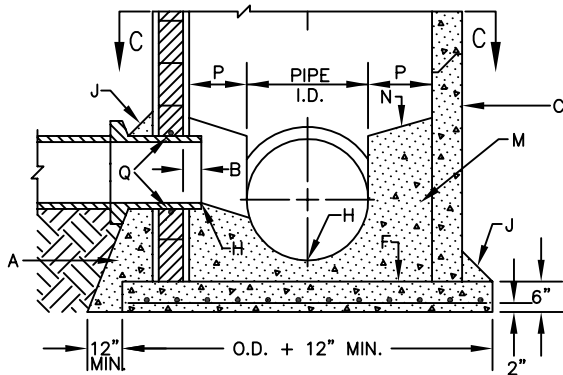
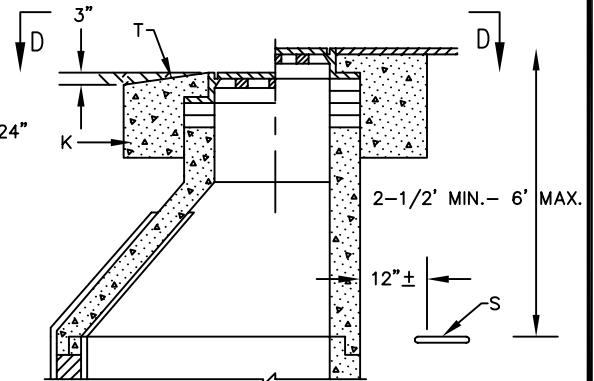
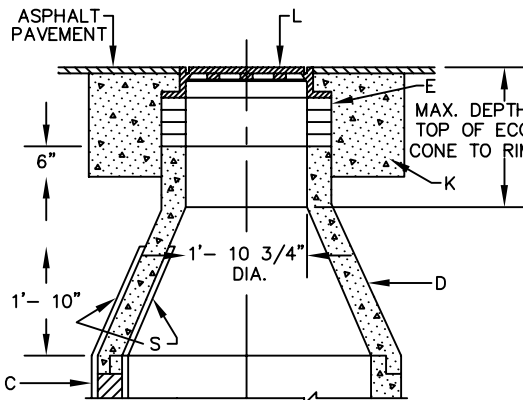

CROSS SECTION A-A

CROSS SECTION B-B

1. INSTALL NEOPRENE "O" RING ON PVC PIPE AND MORTAR TO MANHOLE FOR TIGHT SEAL.
2. FOR PRESSURE TYPE MANHOLE COVER USE SAME AS SHOWN WITH EIGHT (8) 1/2"X2" BOLTS AND NEOPRENE GASKET. BOLT HOLES SHALL BE PREDRILLED IN COVER AND TAPPED IN FRAME.
3. SAS SERVICES MAY BE CONSTRUCTED INTO CONCRETE MANHOLE BASES WHERE NEEDED.
4. IF SEWER MAIN AT A MANHOLE IS TO BE CONTINUED TO A FUTURE STREET, A 20' STUB-OUT TO BE INSTALLED WITH CAP AND WITH 1% MIN. SLOPE.
5. IN UNIMPROVED AND UNPAVED ROADS, MANHOLE RIMS AND CONCRETE COLLARS ARE TO BE INSTALLED AT EXISTING ROAD GRADE.
6. IN OFF-SITE AREAS, ELEVATIONS OF MANHOLE RIMS AND CONCRETE SHALL BE INSTALLED 6" ABOVE NATURAL GROUND.
7. 12" MAXIMUM OF ADJUSTMENT RINGS TO BE USED ON MANHOLES.
8. NON-SHRINK MORTAR INSIDE AND OUTSIDE OF MANHOLE JOINTS.
9. USE JOINT COMPOUND IN ALL MANHOLE BARREL JOINTS.
10. MANHOLES CAN BE TYPE "C" OR "E"

City of Rio Rancho Public Infrastructure Department

APPROVED BY: R. Carroll

TITLE:

STANDARD CONCRETE MANHOLE

DATE: 7/15/08

PUBLIC INFRASTRUCTURE DEPARTMENT ENGINEERING DIVISION



DATE: 7/91
REV.: 7/08

STANDARD DRAWING S-3 (1 OF 2)